

NORTHERN CONSTRUCTION: SITING & FOUNDATIONS

By Eb Rice

(This is the second in a series of articles by Dr. Rice on building in the North. The first, "Permafrost—Its Care and Feeding," appeared in The Northern Engineer, Vol. 4, No. 2, Winter 1972)

INTRODUCTION

A hundred years ago the inhabitants of the North included mostly Eskimos, Indians, Lapps and various Siberians. Their dwellings were admirably adapted to their ways of life; and some of these structures exhibited ingenuity and command of basic scientific fundamentals that deserve study and emulation even today. Now, however, as "southern people" move into the northlands, and as northern people seek to avail themselves of the culture of the 70°F environment, the design of dwellings will need to incorporate special parameters.

Stefansson, during the 1920's, bemoaned the fact that, in the American north, beaches once abundantly supplied with useful driftwood had become barren. Old-style houses, semi-buried and warmable by the heat of the occupants and their cooking lamps, were being abandoned for fuel-hungry frame dwellings like those of the newly-come traders, missionaries, and government men. To people experiencing a transition from nomadic life to a settled existence near church, school and store, mining the beaches for fuel was but a small price to pay for a house that could be lived in all year round—one whose floor would not turn to mud with the coming of spring, and one which could have real windows. No matter that firewood was becoming scarce. No matter that the new houses cooled swiftly and bitterly when the fires died. No matter that drafts were frequent and biting: this was the way of the

affluent newcomer, and what he could endure, all could endure for the sake of status, style, and year-round occupancy. So people, native and newcomer, contrived to exist in uncomfortable, costly, inadequate dwellings. Neither newcomer nor native seemed to be aware that the temperate-zone dwelling was not always adapted to the Arctic. Indeed, as a fervent pioneer once said in an attempt to persuade me of the futility of striving for comfort and economy, "When you hire out to come to Alaska, you hire out to be a 'tough man'...." It was unworthy, he figured, for a dweller in the last frontier to be thinking of comfort. And as for economy, one would be amazed at how much fuel he could save if he never removed his furs and mukluks.... Stefansson probably was giving much the same message: if one lived in the old ways, toughly, there would be plenty of driftwood for all.

But frontier-toughness is in for a change. The northern resident demands and gets the comforts normal to the temperate-zone: the flush toilet, the heated bath, the centrally heated house, running water, and even the attached garage. This is thought to be merely our due. If people live like this "outside," the feeling is, we should live no less well in the North.

Trouble is, these comforts and conveniences were developed for temperate places during many decades. To reproduce them in the northland without knowledgeable modification sometimes results in total failure, and *always* results in extra, unnecessarily high costs, now and forever.... I say "unnecessarily high costs" because careful attention to the particulars of the northern environment can and must reduce to a minimum the inevitably high costs of building modern dwellings in the North. And northerners are properly becoming impatient with the inadequacy and costliness of the hasty and careless adaption of the temperate-zone house to the frigid North.

SITING: SLEEP, SNOWDRIFTS & SUN WORSHIPPERS

Choose the Site Wisely

Special care is needed in siting the arctic dwelling for a number of reasons. For example, in warmer regions the sun rises high overhead on every cloudless day; in the polar regions the sun is never high, and in winter it may not even rise at all. A site that fails to make maximum use of the horizontal southern sun is therefore one to be shunned. This is true in the sub-arctic as well. Even there, the difference between south-facing slopes and other terrain is pronounced. The variety and health of vegetation on sun-facing slopes attest to the favorable climate to be found there. In the Fairbanks area—typical of the "zone of discontinuous permafrost"—slopes facing south are usually without permafrost. Other slopes, together with poorly-drained flat ground, are often underlain by ice-rich ground. Such sites are "possible" building sites, to be sure. But for reasons of psychology (one can see the sun in the south) as well as for terrain, the south slope is much to be preferred and cheaper, too, in the long run.

Of course, a site is selected in the North, as elsewhere, to be conveniently close to water, to transportation, or to a place of work. But once these constraints are satisfied, a dwelling should be placed on ground that will not become a quagmire when thawed. Roads may be needed, and so may waste water drainage areas and recreational space. A "view" is desirable.

There are a few other controls that should be considered in the North, as well. Wind in the treeless tundra is a force to be reckoned with, and shelter from it is much to be desired. But constant arctic winds can deposit an enormous amount of snow, quite capable of filling completely a sheltered cove. Moral: either move to the wooded taiga where

Dr. Rice is a Professor of Civil Engineering at the University of Alaska, Fairbanks, and does consulting work in both City and Regional Planning and in Arctic Engineering.

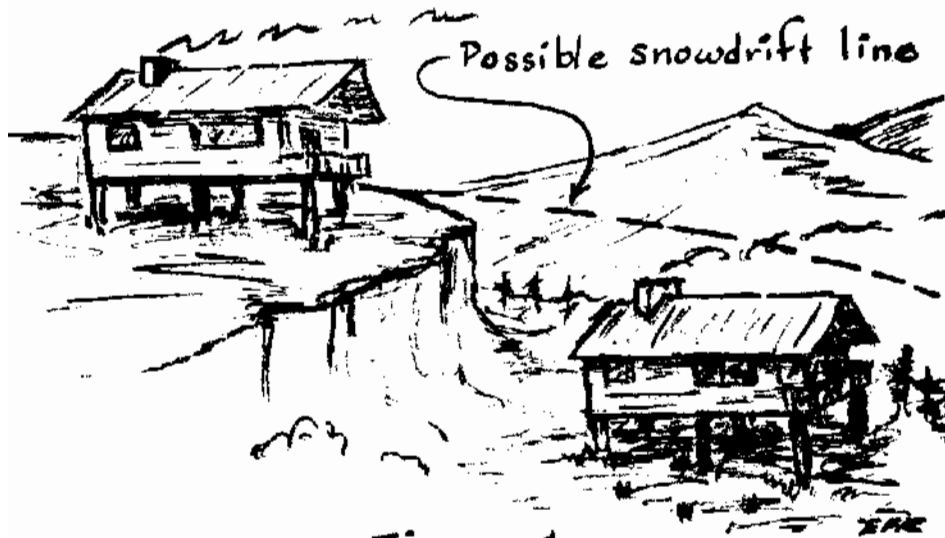

Figure 1
Beware the "cozy" site....

drifting is minor, or locate on exposed plains or ridge tops. Flood plains can be used, if care is taken (proper arctic foundations tend to be more or less flood-proof), but mountainous terrain may have avalanche areas which are strictly to be avoided (Figure 1).

Which Way Should a Dwelling Face?

Woodsmen traditionally placed their tents so that the door faced east—the rising sun was expected not only to waken the occupants early, but also to erase the night's chill. Religious structures were also oriented with their altars to the east (and thus their main entrances to the west). Mosques are supposed to face the Kaaba in Mecca. Most dwellings, if given ample land, are placed facing the "view," or at least facing downhill. What about the Arctic house? Does it matter which way it should face?

This topic should perhaps remain a matter of personal preference, as well as a matter of semantics about what constitutes the "face" of a building. There are, however, some pertinent parameters. The first sun in the spring, for instance, appears briefly at the southern horizon. It is amazing with how much eagerness the daily lengthening of the sun's path is watched. No one who has lived through

the arctic winter will discount the desirability of having windows on the south, with perhaps a sheltered outdoor area as well, to accommodate springtime sun worshippers. Conversely, newcomers tend to want few openings on the north side of

a dwelling for they prefer to sleep undisturbed by the horizontal rays of the summer's midnight sun. My own preference is to place the side with the best windows toward the view (south), down slope (south), and capable of admitting the noontime sun (south). But I like windows facing all the other directions, too.

Shovel, Shovel, Toil & Trouble

Snow drifting can be important, for snow drifts are not merely marvellous sculptural elements: drifts can become frustrating or even disastrous at an arctic site. In the high arctic, winds blow continuously over the treeless plains, and winter lasts for many months. Snowdrifts are not limited, therefore, by the availability of snow or by the wind of a single storm: snow can accumulate in virtually unlimited quantities; and if one has to dig his roadway or outbuilding out of a drift early in the autumn, the project may continue every day, all day, until late spring. It is therefore vital to locate roads, entryways and storage areas away from the downwind side of any building that obstructs the wind's free

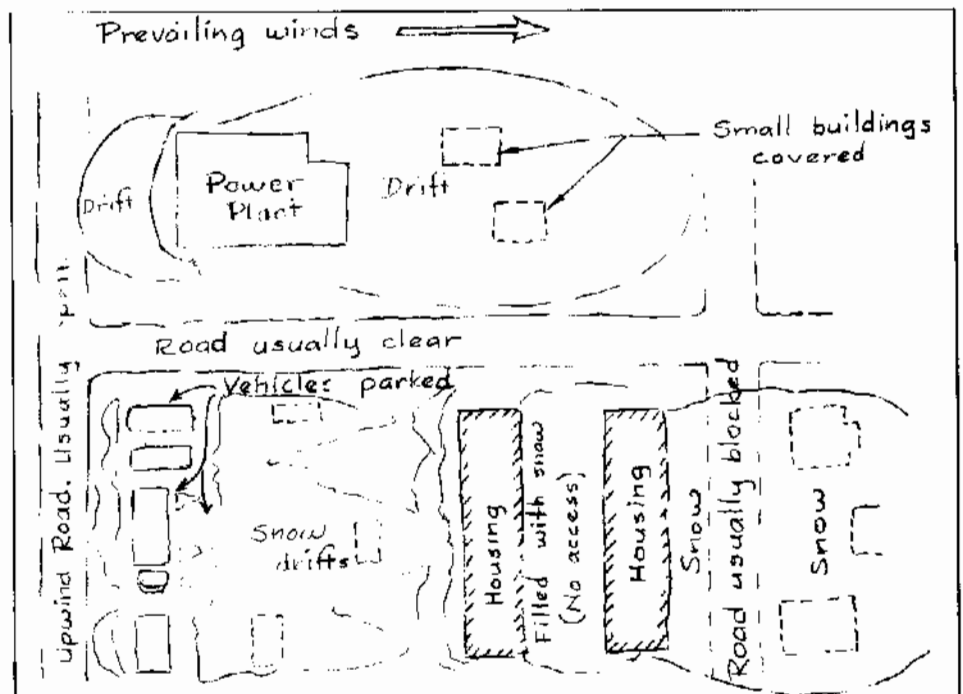

Figure 2
Snow Drifts Make a Difference--This Site Plan Will Not Function

flow. And the building should, if possible, be aligned with its narrowest face toward the prevailing wind. Even vehicle parking must be carefully arranged so as to discourage drifting (Figure 2).

SO YOU'RE ACTUALLY PLANNING TO BUILD IN THE ARCTIC? *

Foundations Unlimited

There's a chance that your arctic site is underlain by clean sand, gravel, or bedrock. If so, you are lucky indeed: even when frozen, such materials do not heave appreciably during freezing, nor settle when thawed. Cases are known where massive ice occurs in gravels and sands, of course, but they are rare enough to qualify as exceptions—and the exceptions may be handled the same way as ice-rich ground is.

For it is the presence of high-ice-content ground that is the chief source of grief in the construction of structural footings. If the soil is free of massive ice, it can be thawed without settling, and you may use the same types of footings common at lower latitudes: piling, foundation walls, slab-on-grade, or spread footings. No special arctic restraints will be needed. In fact, with such materials even the control of heat flow, which is so important for most arctic foundations, is unnecessary. And the "skirting" of buildings, which is anathema in ordinary arctic construction, actually has some advantages when the ground is free of massive ice.

The Exposed Bottom

Corbusier has suggested that large buildings be elevated on massive columns (pilotis) so that the bottoms can be seen by the passers-by. This, he claimed, gives a better feeling for their volume, so that the structures can fulfill properly his dictum that a house is "a machine for living." The prehistoric Swiss lake-

dwellers elevated their structures on piling above the waters, partly for reasons of defense, partly for convenience. Tropical peoples in many areas elevated their houses on posts, too. Mostly this was for defense against rising flood-waters, but possibly also to quell somewhat the need to share the dwellings with livestock, insects, or other casual tropic fauna. **

However useful or aesthetic it may be to elevate structures above the ground in other climates, in the Arctic, where the ground is so often fat with ice, it can be vitally necessary. To place a heated structure against the ground is to thaw that ground—and when ice-rich ground thaws, no structure on it is likely to survive.

The very essence of structural survival is to prevent the buildings' heat from

reaching the ground, and to make certain that the foundations are permanently immobilized in the frozen soil. This means separation of the heat source (the house) from the ground. Let us take this opportunity to dispel the idea that insulation alone will suffice: *it will not*. Insulation, whatever its virtues in other contexts, can never *stop* thaw penetration; it can only *delay* the inevitable thaw. To repeat: total separation of ground from heat source is vital. Insulation alone cannot substitute for separation. Much as we may abhor the idea of allowing winter to pass freely beneath our floors, there are no inexpensive alternatives, nor are there likely to be. (True, any good arctic engineer can devise a way to extract heat without elevating the structure, but he must be good indeed if his solution is to

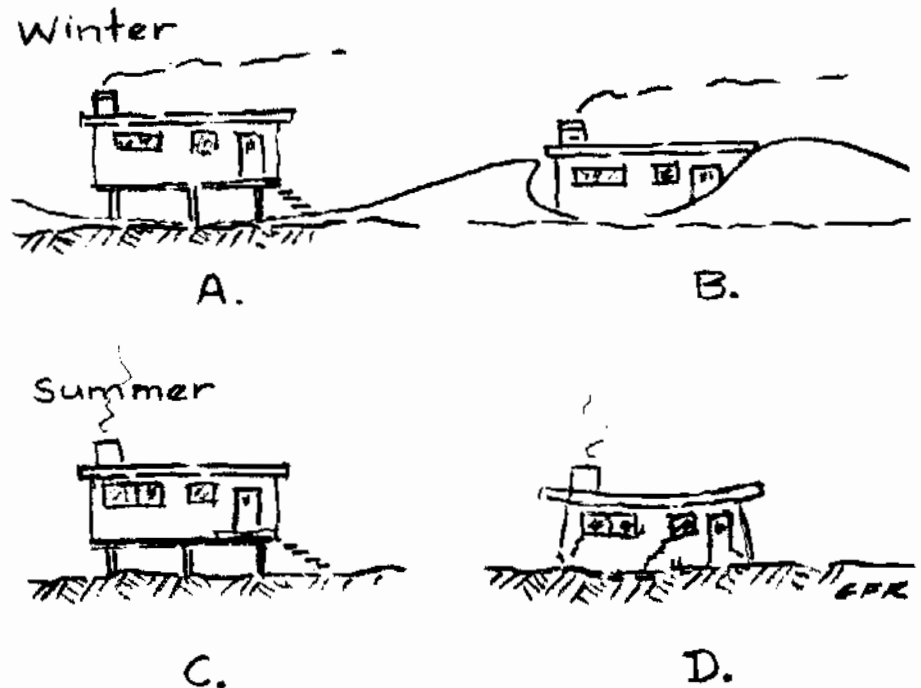

Fig. 3
The Elevated Structure
(Drifting & Thawing Can Be Exciting)

*Or sub-Arctic. "Arctic" is where permafrost is continuous (See: "Permafrost, Its Care and Feeding," The Northern Engineer Vol. 4, No. 2, Winter, 1972). In the sub-Arctic you have a good chance to find a permafrost-free site, in which case, your problems are minor.

**Elevated houses also are easy to keep cool. It is doubtful that this virtue will have a strong appeal in the Arctic.

be competitive.) Why do we "expose the bottom?" Let me count the ways....

First, a structure elevated high enough to allow the unimpeded intrusion of winter between itself and the ground will remain stable, for its foundation can be easily contrived to remain frozen in place. Second, an elevated structure can be installed with an absolute minimum of disturbance to a site: no alteration of drainage patterns, no massive excavation, no necessity for destruction of organic ground cover need occur (although I recommend a gravel pad over the area for fire and mud control). Third, the elevated structure is the only enclosure, other than a buried one, that will not promote severe snow drifting in the vicinity.

To these three main reasons for elevating the structure, we may add the following: the elevated structure is, or can be, flood proof. It is cheap and easy. Its simplicities commend it for construction by inexperienced builders under difficult conditions. If, somehow, it should fail, the structure can be simply and easily restored to rights. And piles, posts, and piers of a suitable type for foundations are comparatively easy to transport—even by air—to most arctic locations (Figure 3).

Unluckily, an exposed bottom can get cold. Maladroit designs have resulted in floors so uncomfortably cool as to encourage occupants to "skirt" structures with some kind of sheathing to protect the "crawl space" beneath the building from winter's cold. Such skirting can be used, carefully, for structures in the high arctic, where the ground temperature is quite low. But skirting can be disastrous in areas of marginally warm permafrost, as at Fort Yukon, Bethel, or Glennallen. In these areas, the frozen ground is only a degree or so colder than the thaw point; and there is very little reserve to accommodate heat inputs in addition to the summer flow. So a thaw bulb forms

****I regard this as an architectural or engineering failure: if the design leaves occupants so uncomfortable that they are impelled actually to do something, the failure is no less serious than if the foundation design had been inherently faulty.*



FIGURE 4. Sometimes "on-grade" construction can be disappointing.

which ultimately may include the foundation. Dramatic failures have occurred to foundations which were initially well designed and constructed, but which were skirted by the occupants to improve comfort and utility. ***

To summarize: despite the cold hazard to the exposed bottom of a building on a foundation of piles, posts, piers or pilotis, there are many virtues that recommend it for arctic construction. Among these are two salient ones: (1) the heat segregation inherent in elevated construction protects against the leakage of heat from the structure into vulnerable, ice-rich ground, and (2) pile foundations promote the unimpeded flow of arctic winds, so that serious snow drifting is discouraged. Together with simplicity, flood proofness, economy, snowdrift control, and environmental suitability, these two make the thermal isolation of a dwelling by elevation a nearly unbeatable technique for construction over icy terrain. **** (See Figure 4.)

Are There Alternatives?

There are alternatives to the elevated structure but not, unfortunately, to cold bottoms. No warm surface can be juxtaposed to icy ground without causing the ice to melt, even if separated by generous layers of insulation. Where loads are heavy and perhaps concentrated, as in aircraft hangars and heavy-equipment repair shops, elevated floors are not so practical. In such cases engineers have devised ways of keeping a floor's underside suitably cold while still carrying the heavy loads directly to the (frozen) subgrade.

In Thule, Greenland, for example, the design engineers provided a heated hangar for large aircraft. It is of more-or-less conventional slab-on-grade construction, but the slab is special. The concrete floor is underlain by strong foam-type insulation. The insulation rests on another concrete slab on a thick gravel pad. The key to structural security of the design lies in this under-pad of gravel. It is filled

*****If you've wondered why there are so many footnotes in this part, contemplate this: no engineer would be likely to recommend an exposed bottom (with piles) in the Arctic, unless he had an extra *.*

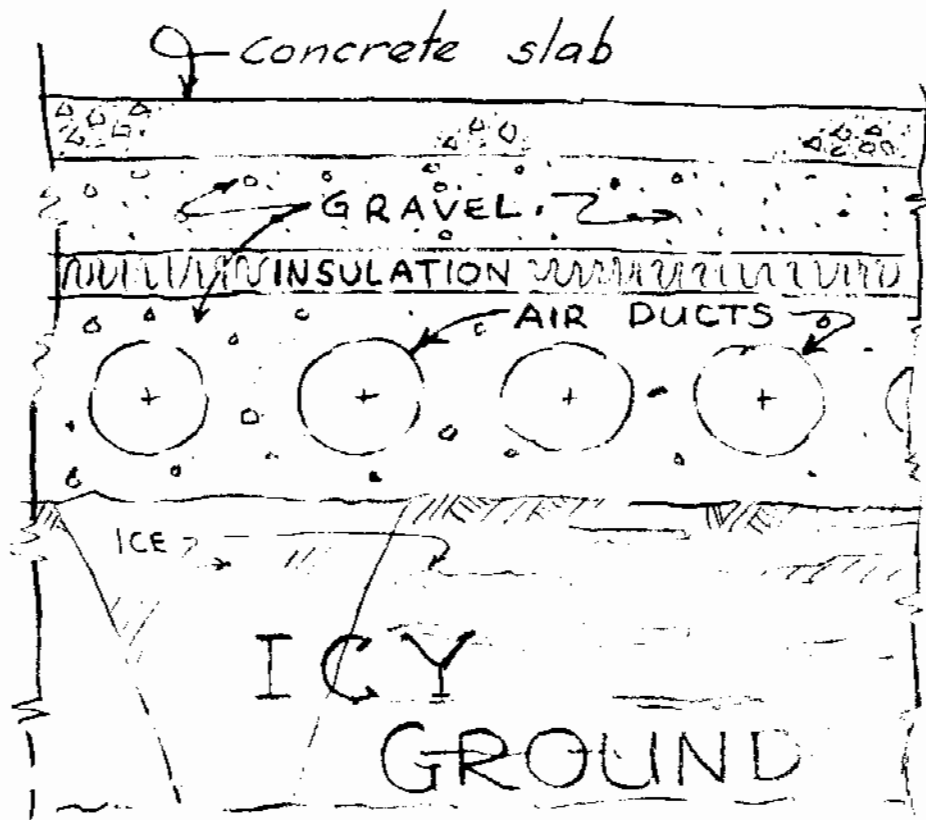

Fig. 5

A Cold-Bottomed Slab

with large culvert pipes, laid side by side, and so arranged that, in winter, cold air will flow through to cool and protect the underlying ice from melting. In summer, the pipes are kept closed to minimize the heat flow into the subgrade during the short summer. In several Alaskan installations a similar technique is used: heat which finds its way through the insulation under a floor is intercepted by a lacework of mechanically refrigerated tubes. The heat is dissipated harmlessly above ground. In a similar fashion, one-way heat tubes and their modifications show considerable promise in using "natural cold" to protect the underlying permafrost from thawing (Figure 5).

PILING

Placing the Piles

Piles are posts or poles placed in the ground to serve as structural supports. In

tropic and temperate-zone construction they are often used but rarely visible, located as they usually are beneath the lowest columns of a bridge or building.

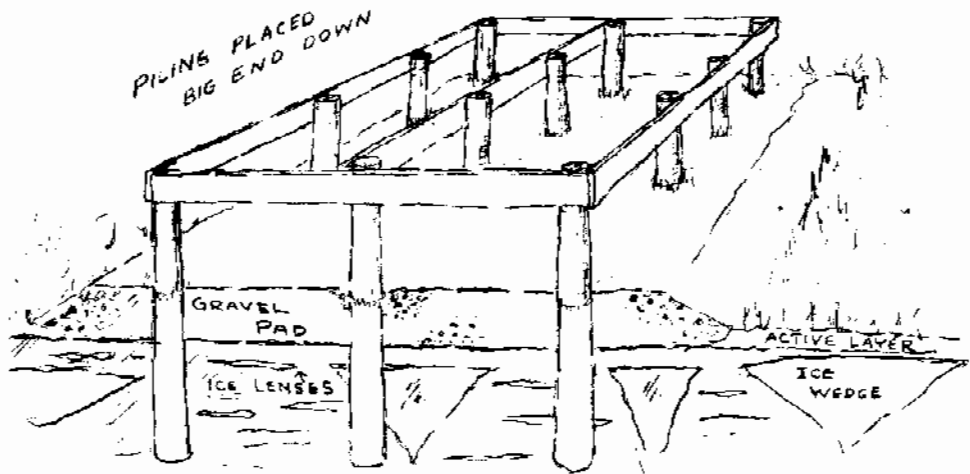

Fig. 6
Typical Pile Foundation

For marine construction they are ubiquitous: most piers are built on piling because it is comparatively cheap and quick, and because pile construction minimally obstructs the passage of waves and currents. For arctic work, piling is popular because it is the simplest way of providing thermal isolation of a heated structure, and also because it is strong and permits easy passage of drifting snow or flood water. (Figure 6).

Piling is placed in many ways: "pile-driving" is popular for wood, steel, or concrete piles in soft ground. What is not commonly realized is that steel piling (both open-end pipe piles and H-piles) can be successfully driven into fine-grained or peaty permafrost. Piles driven into ice-cemented gravel, however, occasionally come to grief (Figure 7). Vibratory pile hammers are showing considerable promise in this area, although double-acting steam, air, or diesel powered hammers also work well, if extra large.

Commonly, piles of wood or concrete have been placed in holes melted into the frozen ground by steam, hot water, or electricity. (They cannot be driven into frozen ground.) Ideally, the hole should be thawed swiftly so that its width is but little more than the thickness of the pile. The pile may then be driven into the hole with conventional pile-driving equipment. Possibly more piling has been placed in this way than in any other fashion in the Arctic. And yet, it is not the best way: depressing failures have occurred because structures were placed on such piles be-

fore they had time to freeze back. It is obvious, upon reflection, that a column of hot muddy water, filled or not with a pile, is a heated pocket destined to enlarge prior to finally freezing. If only surface-freezing has taken place, as often happens in the Arctic, a sturdy looking, solid-feeling pile may be built upon, in

augers, if equipped with very sharp teeth, will penetrate frozen silts, sands, peat and ice quite swiftly. (No cheap and easy way of penetrating ice-cemented gravel or bouldery ground is known to me, and in such ground the driving of piles into thawed holes will probably remain the best way for some time to come.)

be different. The active layer may be thick—up to five meters—and the permafrost is warm, weak and willing to thaw. The task of designing a foundation in such locations is formidable. Decay may be a problem, lateral loads may become significant, and, worst of all, "heaving" may be so severe as to warrant elaborate

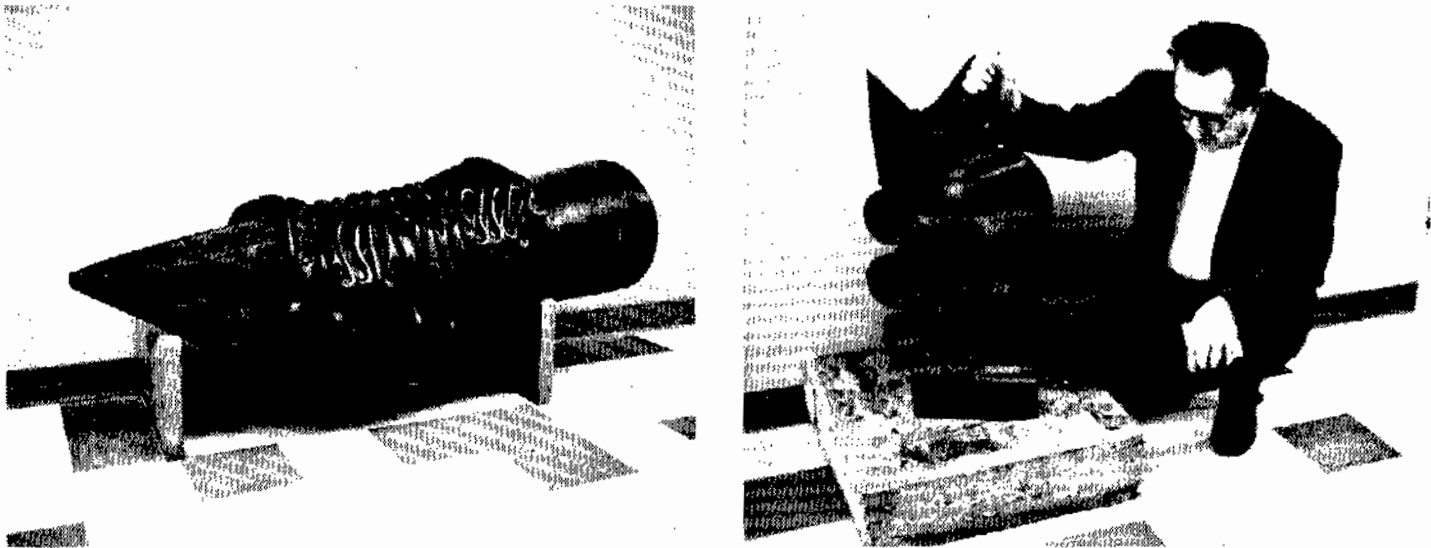

FIGURE 7. Avoid driving piles into ice-cemented gravel.

the belief that it is solid. Often it isn't, and the results are disappointing. This happened many times during the construction of the DEW (Distant Early Warning) Line in the north of Canada and Alaska in the early 1950's; and later, during the construction of Inuvik, NWT, Canada, the hazard was considered so real, and the freeze-back time so uncertain, that it became customary to place piling in the fall of the year, so that freeze back would be surely complete in time for spring construction.

A third way of installing piles is to place them in drilled holes. This method, where applicable, has nearly superseded others. A hole, somewhat larger than the pile itself, and deep enough to extend well below the maximum expected thaw depth, is drilled into the permafrost. The pile is then simply dropped in the hole, braced in place, and backfilled with material previously excavated from the hole, or with gravel, or other selected material. Since no appreciable heat is inserted into the ground, the pile is ready for use as soon as its backfill is compacted.

The holes are usually drilled by auger-type drills mounted on vehicles for easy portability and convenient setup. Such

Some engineers recommend backfilling piling with a slurry made of sand, silt, and water. Some argue that the proportions and quality of sand and silt are important: they write elaborate specifications governing the mixing and placing of such backfill. Doubtless, where a builder's crew cannot be trusted to compact properly the annulus around the pile, the slurry method may have merit. But I would favor, in that case, a backfill of free-running sand or gravel. This is easier, requires no special equipment, and is *much* cheaper. It is just as good, or better, and what's more, dry fill rarely adds appreciable heat to the ground.

Immobilizing the Pile or Pole

In the high Arctic, the piles can be short, and they act as end-bearing piles. Their depth of burial must be sufficiently far below the depth of maximum thaw that they will give adequate lateral support (for wind or earthquake) during the thawing season. No further precautions need be taken, as a rule, for in such regions the active layer is thin and the permafrost is cold and strong. Decay of wood is slow and rarely critical in the high Arctic.

In the sub-Arctic, though, things can

and expensive countermeasures.

In such places a pile foundation is the preferred type: in fact it is difficult to think of a reasonable alternative. In the selection of a foundation, the designer first assures himself that it will handle the expected loads. Then, especially in the sub-Arctic, he must consider the other problems:

Will it Heave, Rot, Melt, Settle, or Lean?

One way to make certain that a foundation does *not* do any of these evil things is to keep the piles frozen in place, as they would be in the high Arctic. This can be done through extraction of heat throughout the summer, or by so thoroughly overcooling the ground in the winter that there is insufficient time in the summer to complete the thawing of the foundation area. There are several ways to accomplish this, all of which can be expensive. But sometimes a permanently frozen condition of the foundation is the surest solution, and often it is cheapest among the alternatives. Methods of achieving a permafrost-stabilized foundation range from mere snow removal and shading, through provision for massive heat extraction in winter, to elaborate refrigeration systems. In general, heat

extraction in winter through the use of automatic thermal valves (the Long "Thermo-valve," the Thermodynamics "Frost-Tube," or the MacDonnell-Douglas "Heat Pipe," for instance) is possible. A somewhat less sophisticated, but still effective, way of using winter's cold to maintain summer permafrost is Rice's "Brute Force" system—a simple arrangement of pumps, pipes and heat exchangers which is operated in winter and shut down in summer (Figure 8).

Where a permanently-frozen footing is impractical, other means of stabilizing piles must be used. Permanently *thawed* footings involve no special problems in areas where there is no permafrost. But oftentimes foundations in the sub-Arctic can neither conveniently be kept frozen *nor* thawed: there will be an active layer and this spells trouble. With the periodic freezing of material near the foundation there can be serious yearly deformation due to frost heave. This causes a phenomenon known as "frost-jacking" of piles, which is an insidious process which causes piles to heave upward during the cold season, with no countervailing tendency to return to the original level when thawed (Figure 9).

The mechanism is simple enough, yet not widely understood. Figure 9a shows the freezing front beginning to penetrate the frost-susceptible ("heavable") **** soil. Ice lenses are forming, forcing the frozen layer upward. The pile, which is frozen solidly to the heaving layer, goes up with it. This process goes on, and the pile continues to rise so long as ice layers continue to form. In Figure 9b the heaving is complete, and in Figure 9c summer has come, thawing the upper layers. Excess water rises to the surface and is lost, and the thawed soil settles back as the thaw penetrates. By the time the thaw penetrates to the bottom of the active layer, the heaved soil has reconsolidated, and it grips the pile anew (Figure 9d). But the pile is now elevated somewhat, for until the last few inches of frost were melted, it was held in its raised position by a frozen grip.

This jacking process is the chief source of deformation of pile footings. Fortunately, something can be done about it

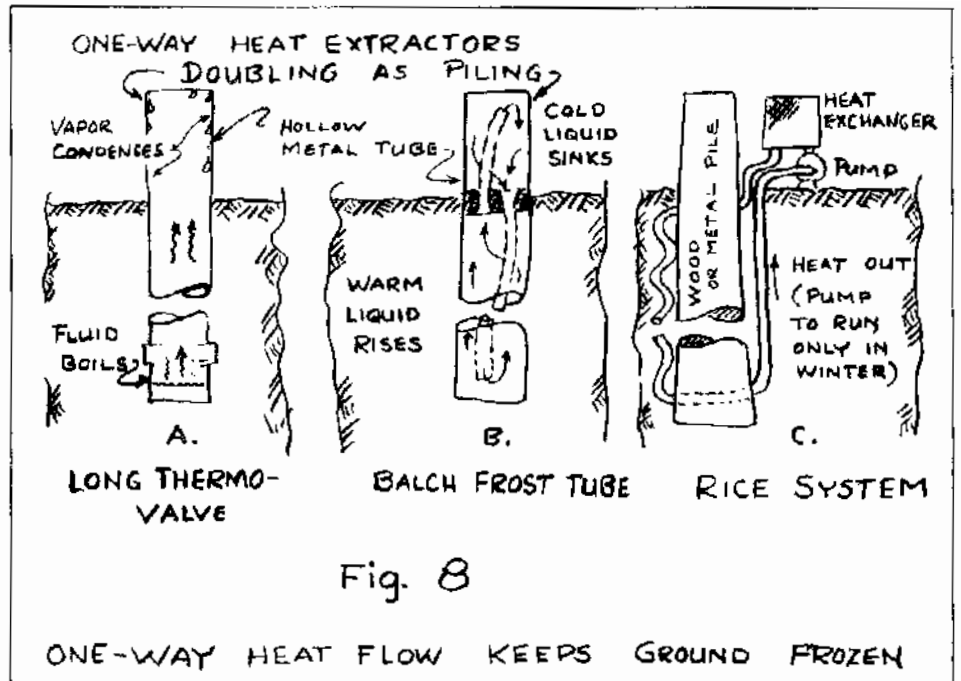

Fig. 8

(Figure 10). If some kind of mechanical anchor is attached below the active layer, resistance to heaving can be enormously increased. Or if some method is employed to make the pile too slippery for the frozen ground to hold, the heaving forces can be reduced. So there are really five things that can contribute to safety against pile jacking:

(1) Never let the surrounding soil

- freeze, or
- (2) Never let it thaw. Or,
- (3) Anchor the pile against uplift, and
- (4) Break the bond in the active layer, or
- (5) Place piling only in non-frost-susceptible soil

If it's a wooden pile, of course it should be placed big end down.

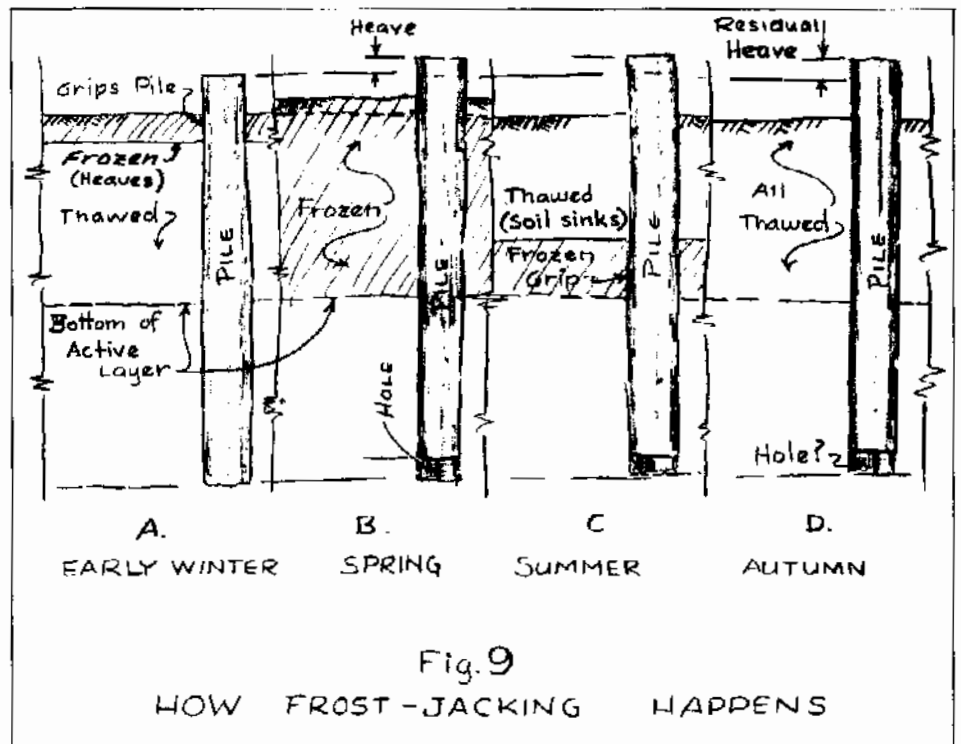

Fig. 9

HOW FROST-JACKING HAPPENS

****Siltless soil is usually non-frost-susceptible, and non-troublesome.

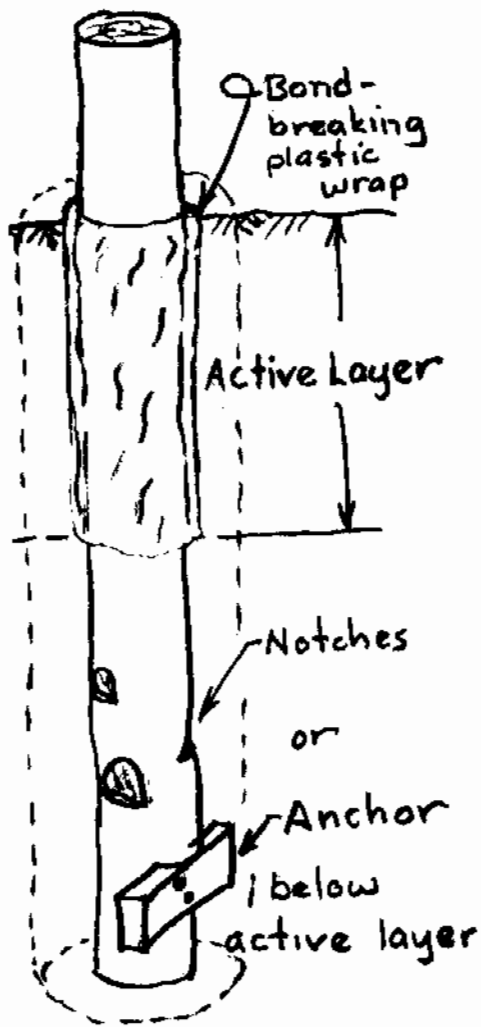
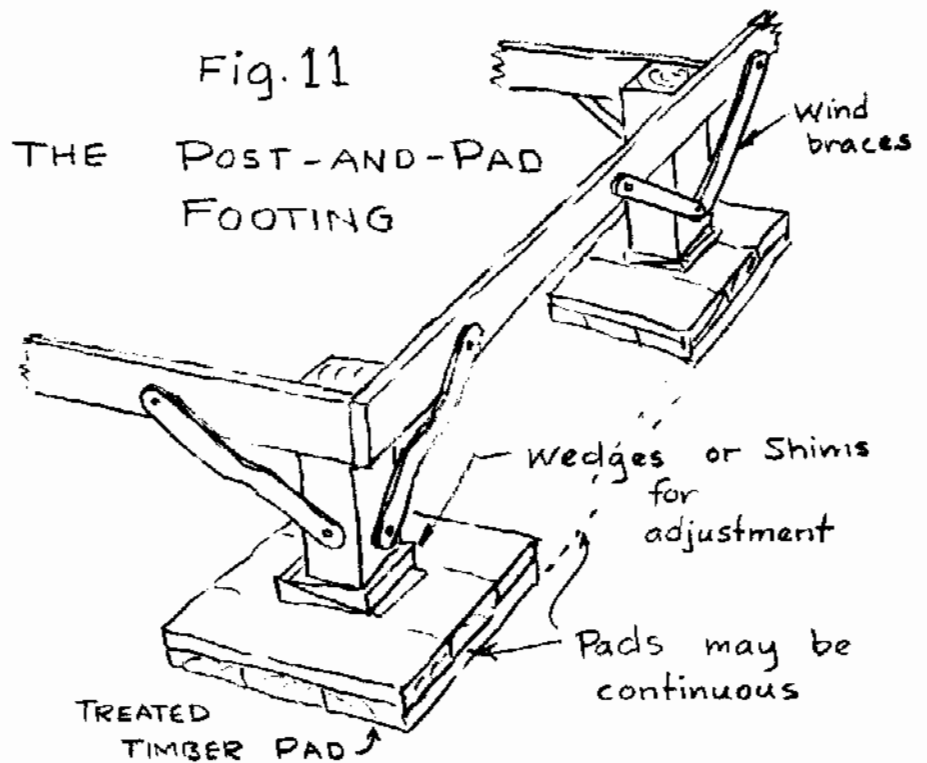

Fig. 10

HOW TO "JACK-PROOF" PILES

POST-AND-PAD: A "SOMETIMES" SOLUTION

Sometimes, piling is impractical. Maybe there is no equipment available to drill holes. Possibly piling is too bulky to ship with the transport available (for example, to a remote hunting lodge served by small airplanes only). Or perhaps the ground is unsuited to a foundation of piling. In such cases, where separation of structure and ground is needed, post-and-pad construction can be used. In this kind of foundation, pads (usually of timber) are placed on, or in the top few inches of,



the soil. Posts are erected on the pads, and the building is constructed on the posts as if they were piles embedded in the world. Figure 11 shows how this might be accomplished.

Are There Problems?

If post-and-pad footings are used over "bad" ground, where heave or settlement can be expected, then of course, the supported structure will heave or settle. This will rarely be uniform, so the building will also wrack. The key to successful use of such a footing is therefore (1) to select "good" ground—that is, bedrock or iceless sand or gravel, or (2) to provide the means and personnel to monitor the level of the building's floor and adjust it as needed (which is to say, often).

This will require underfloor access for jacking equipment, together with shims, wedges, or turnbuckles to adjust the structure to its shifting foundation. I suggest that architects and engineers, in choosing such a foundation, do so with caution—one is entrusting the integrity of his structure to the whims of a capricious Nature, and still more to the skill, sobriety, or availability of some future workman.

DENOUEMENT

The Site's Right....

When the problems of psychology, view, radiation, drainage, drifting, flooding, convenience, and utility have been reconciled, and the designer is ready to begin his plans, and such features as roads, water supply, and waste disposal have been agreed upon, it is time to think of selecting a foundation type.

How Firm a Foundation?

In the Arctic and sub-Arctic one can be certain that a solid foundation is possible if underlying permafrost stays frozen. This usually means that the structure should be isolated from the ground by piles, piers, posts, poles, or pilotis to prevent heat input to the foundation soils. Once this decision is made, subsequent decisions must be made about how to make sure a cold bottom does not cause a cold floor, for a cold floor may be hazardous to your toes, and, ultimately, to your structures.

Next Time

In the third installment of this series on building in the North, we will attempt the inside story on insulation, and on windows, walls, doors and floors. ★