



BUILDING IN ALASKA

EEM-00954

Effect of Studs on the Heat Loss and Insulation Value of a Wall

by
Richard D. Seifert,
Energy and Housing Specialist

A considerable amount of heat is lost through the wall sections of frame buildings where studs are located. Depending on the size of the wall (2' × 4', 2' × 6', etc.) and the spacing of the studs, the heat loss through framing can vary from 33 percent to 49 percent of the total. Some of these calculated values are shown in Table 1. These calculations are based on a typical section of wall, 8' × 8' in area, to provide a comparison of the effects that studs have on the heat loss through a wall. The comparison of different stud spacings for a 2' × 4' stud wall is given in Table 1 along with the percentage of total heat loss due to the studs. The effect is quite significant.

As shown in this example calculation in Table 1, as much as 44 percent of a wall's heat loss can be through the studs. This results in some common problems in Alaska buildings.

Condensation is a very common problem in Alaskan houses. It often occurs on windows, at cold corners or at the top or bottom of a wall, and on sheet rock nail heads. This is because the nail shank penetrates the framing members and cools more rapidly than the adjacent sheet rock. The tip of the shank is exposed to a lower temperature (and greater temperature difference) within the stud. With an outdoor temperature of minus 40°F and an indoor temperature of 70.0°F, it is estimated that a 1½-inch nail would have a temperature of 54.8°F, while the surface of the sheet rock would be 58.7°F. Condensation on the nail heads would occur at relative humidities greater than 56 percent.

Condensation of soot often becomes visible as painted surfaces darken over framing members because the framing members are cooler than adjacent insulated surfaces.

Table 1. PERCENTAGE OF HEAT LOSS THROUGH A STUD WALL
(8' × 8' Example Section)¹

STUD SPACING	Heat Loss Through Studs		Heat Loss Through Insulated Section		TOTALS	
	BTU/HR/°F	Percent of Total	BTU/HR/°F	Percent of Total	BTU/HR/°F	Average R-value
— ²	—	—	4.89	100%	4.89	13.1
24 inches o.c.	2.03	32%	4.37	68%	6.40	10.0
16 inches o.c.	2.61	38%	4.23	62%	6.83	9.35
12 inches o.c.	3.17	44%	4.08	56%	7.25	8.82

¹ The example section is a 2" × 4" stud wall, with 3½ inches of fiberglass insulation (R11), ½ inch gypsum dry wall and ⅝ inch plywood sheathing on the exterior, 64 square feet in area.

² This is an example showing the wall heat loss if studs are not present.

The insulated portion of the wall between the studs (R=13.1) would have an interior surface temperature of 64.3°F. The sheet rock directly over the framing members (R=6.61) would have a surface temperature of 58.7°F, such that condensation would occur at around 66 percent relative humidity.

In order to minimize the staining of nail heads and soiling of painted surfaces due to temperature differentials, it is suggested that exposed walls be framed (in new construction) with either 2" × 4" (or better — 2" × 6") studs, 24 inches on center.

In addition, the wall should be insulated with fiberglass batts and a 1½-inch foil-faced insulating board placed on the **inside** of the new wall. This has several advantages. 1) It utilizes the vapor barrier properties of the foil-faced insulation on the warm side of the wall. 2) It will completely cover the studs and shield them from direct contact to the inside of the wall adding a rated value of ~R-10* (commercial rating information) to the wall insulation which is dependent of the thickness of the insulation used. In

*These are maximum board stock rigid insulation numbers (R-values). Use of polystyrene insulation boards will result in less insulation value per inch.

the case of a 2" × 4" wall with 3½ inches of fiberglass and studs 16 inches on center, this would result in a wall with an R-value of 19.35 instead of the average R-value of 9.35 for a 2" × 4" stud wall.

The installation of boardstock insulations is preceded by a 6-mil vapor barrier and then crosshatched by either 2" × 3" or 2" × 4" nailers onto which the sheet rock will eventually be screwed. These nailers are screwed directly onto the face of the 2" × 6" framing stud with long screws, typically sheet rock screws, and then the installation of boardstock in-between these horizontal nailers as shown in Figure 1. This allows for electrical runs to be made in the nailer space and prevents perforating the vapor barrier when these electrical runs are made. The nailer should not be set over the top and bottom plates. An indication on how this might be accomplished to insulate the plates, is shown in the second figure, Figure 2.

This wall type (2" × 6" stud base) yields a finished wall R-value of approximately R30. While this wall has some disadvantages — mainly the slight decrease in interior space

continued on page 4

Figure 1. Cross-Section of a Well-Insulated, 2" × 6" Stud Framed Wall

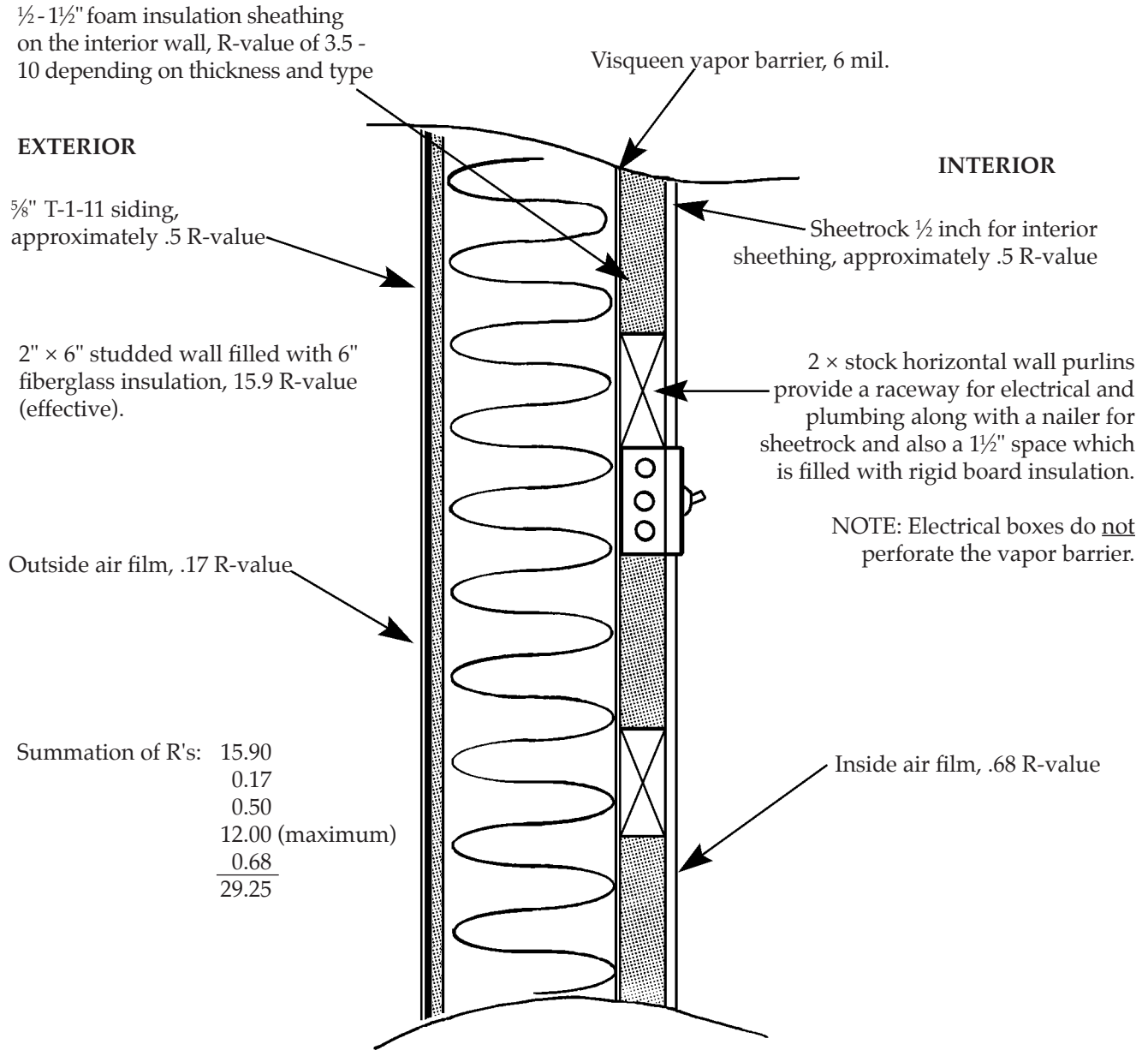

A well-insulated, 2" × 6" stud-framed wall which minimizes the effect of studs by covering the stud wall with a continuous layer of insulation on the inside. An R-value of ~29.25 is achieved using this design.

and the nailing difficulties — it is still a top contender for the most efficient home wall both thermally and economically. This is especially true since the new Alaska State Thermal Standards are in place and many regions of the state which have a cold climate, require a wall which exceeds the standard R-value R-19 of a 2" × 6" stud wall to meet the minimum thermal efficiency

standards. The easiest way to achieve a wall such as R-24 or R-26, would be to use a cross-hatched wall such as shown in Figures 1 and 2.

Note: These thermal efficiency standards for the State of Alaska are given in Cooperative Extension Service publication entitled *Special Considerations for Building in Alaska*, HCM-00952.

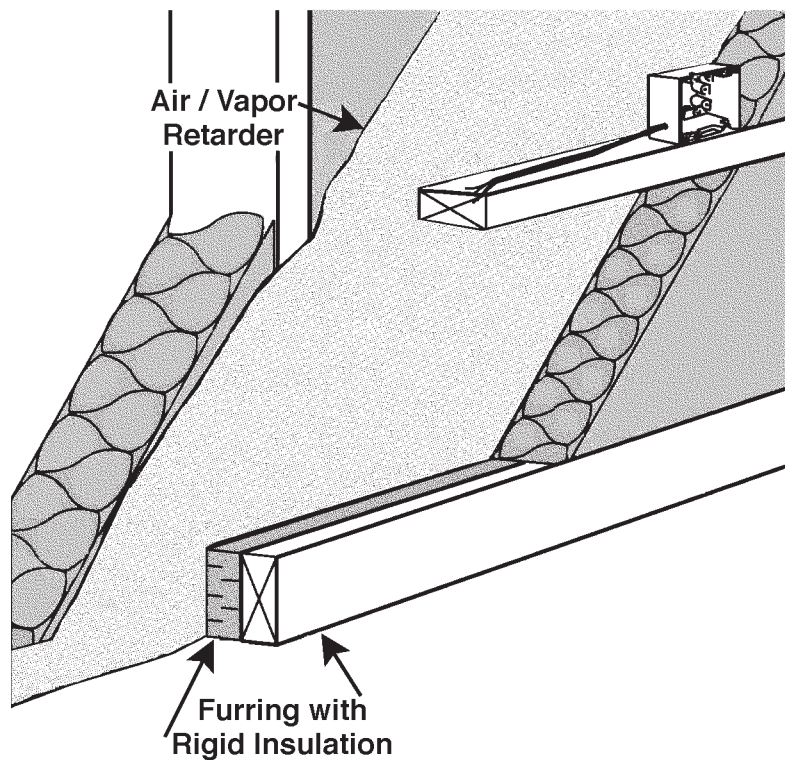

Figure 2. An Alternative Cross-hatch Framing Detail Using 2"×4" Lumber

Visit the Cooperative Extension Service energy and housing home page at www.uaf.edu/ces/faculty/seifert/

2/84/RS/1000

Reprinted May 2007



The University of Alaska Fairbanks Cooperative Extension Service programs are available to all, without regard to race, color, age, sex, creed, national origin, or disability and in accordance with all applicable federal laws. Provided in furtherance of Cooperative Extension work, acts of May 8 and June 30, 1914, in cooperation with the U.S. Department of Agriculture, Pete Pinney, Interim Director, Cooperative Extension, University of Alaska Fairbanks.

The University of Alaska Fairbanks is an affirmative action/equal opportunity employer and educational institution.